

Ergonomic evaluation of cashew nut shelling machine

S. J. Ojolo¹, O.O. Olatunji^{2*}, J .I. Orisaleye¹

(1. Mechanical Engineering Department, University of Lagos, Nigeria;

2. Mechanical Engineering Department, Covenant University, Ogun state, Nigeria)

Abstract: This paper presents the ergonomic evaluation of a manually operated village-level cashew nut shelling machine. A manually operated cashew nut cracking machine was evaluated. Fifty subjects took part in the study, with physiological, postural, and subjective measurements being taken. Comfort Questionnaire for cashew nut cracking machine (CQC) was also evaluated. Using the machine resulted in postural discomfort. The perception of the subjects as per the efficiency of the machine was neutral; 50% accepted that the machine is efficient, while the other 50% were unsatisfied. Following a participatory ergonomic process and using appropriate anthropometric measurements, an improved, adjustable prototype was developed. The lever arm was designed based on 5th percentile of the subjects; blades were welded into the cracking lid to reduce the amount of impact force used for cracking, so as to reduce crushing of the nuts. Also the ergonomic seat and worktable allow posture change from sitting to standing. Other features include; feeding tray, foot rest. The work surface height is made to be 100 mm below the elbow height. i.e. 1200 mm. The length of the work table (work space) was designed to accommodate 95th percentile of the Bicromial breadth of the subjects. The foot and the knee room was 150 mm. The cracking machine is bolted to the worktable, so that it can be easily disassembled. The study demonstrated how ergonomics can play an important role in reducing drudgery and improving user satisfaction and acceptability in technology development and transfer in developing country.

Keywords: cashew nuts; cracking machine; ergonomics; comfort; anthropometric

Citation: Ojolo, S. J., O.O. Olatunji, and J .I. Orisaleye. 2016. Ergonomic evaluation of cashew nut shelling machine. Agric Eng Int: CIGR Journal, 18(1):167-179.

1 Introduction

The main economic characteristic of agriculture in developing countries is the low level of manual productivity. While the benefits of technology have been shown in many and varied circumstances, even rational and intelligent farmers may resist their implementation, so any machine improvement involves a slow rather than instantaneous acceptance (Mahendra and Awadhesh, 2010). This is a factor, which may affect efficiency in any labor operation.

Ergonomics focuses on human beings and their interaction with machines, materials, information, procedures and environments used in work and everyday living (Sanders et al., 1992). The branch of ergonomics that deals with human variability in size, shape and

strength is called anthropometry. Anthropometry refers to the measurement of human beings. Anthropometry has been considered as the very basic core of ergonomics in an attempt to resolve the dilemma of „fitting people to machine“ (Wang et al, 1999). Bridger (1995), and Chou and Hsiao (2005) believed anthropometry is a research area in ergonomics dealing with the measurement of human body dimensions and certain physical characteristics. Anthropometric data can be used in ergonomics to specify the physical dimensions of workspaces, workstations, and equipment as well as applied to product design.

Cashew (*Anacardium occidentale L.*) is an evergreen tropical tree from northeast Brazil, which produces a valuable nut that is widely consumed as snacks all over the world. Cashew nut ranks third among the edible tree nuts of the world with a current output of about 700,000 metric tons nut in shell (FAO, 2004). Nuts may be sold raw or as processed kernels and may be further processed

Received date: 2015-06-23

Accepted date: 2015-10-27

*Corresponding author: O.O. Olatunji, Covenant University, Ota, Ogun state, Nigeria. Email: tunjifemi@gmail.com.

into value-added products such as fried, roasted or chocolate-coated kernels and confectioneries, *etc.*

McNeill and Westby (1999) evaluated a manually operated machine for chipping cassava. This study demonstrated how agricultural machinery developed for use in a developing country can be improved by employing a participative and iterative approach to design, paying closer attention to human factors. By incorporating ergonomics into the design process, drudgery associated with the machine was reduced and productivity, user comfort and satisfaction were increased. Improving the posture adopted to operate the machine resulted in a significant reduction in physical strain and incidence of body-part discomfort.

Kölsch et al. (2003) proposed an objective measure for postural comfort. The proposed method allows for assessment of postural comfort. They determined the comfort zone by measuring compensating motion that allows participants to freely pick a comfortable posture range with the body part under scrutiny. Their method does not rely on acquisition of subjective data. Instead, it is entirely objective and allows for participants that are naïve to the study purpose body part under scrutiny. Mahendra and Awadhesh (2010) carried out the design, development and ergonomics evaluation of hand operated spade (PHAWRA). This paper addresses ergonomics factors that can increase the utility of a hand-operated spade or hoe.

Ojolo and Ogunsina (2007) carried out the development of a cashew nut cracking device. The

device was developed to improve the efficiency of the shelling operation in cashew nut processing. The performance of the machine is fairly satisfactory but an improvement on the percentage of whole kernels is achievable with further modification and testing. They concluded that a device of this nature can be manufactured in small machine shops in the developing countries for small entrepreneurs and village level applications.

Further research is carried out to evaluate the machine base on ergonomic considerations and to improve the design of the machine for better performance and user acceptance. The need to determine a suitable user and machine interface leads us to ergonomic evaluation of the cashew nut cracking device.

2 Materials and methods

2.1 Cashew nut cracking machine design

The cashew nut cracking machine was developed by Ojolo and Ogunsina (2007). The machine was conceived as a village-level, low-cost, simple-to-operate and easy-to-fabricate manually-operated device capable of cracking many cashew nuts at a time. The machine is a simple device, which allows for adjustment and proper alignment of the nuts before cracking. It comprises of four major components assembled together by welding to form a compact device. The components are: the metal casing, the feeding tray which is supported by mild steel box, the cracking lid, and the lever arm. The complete machine assembly is shown in Figure 1a and 1b.

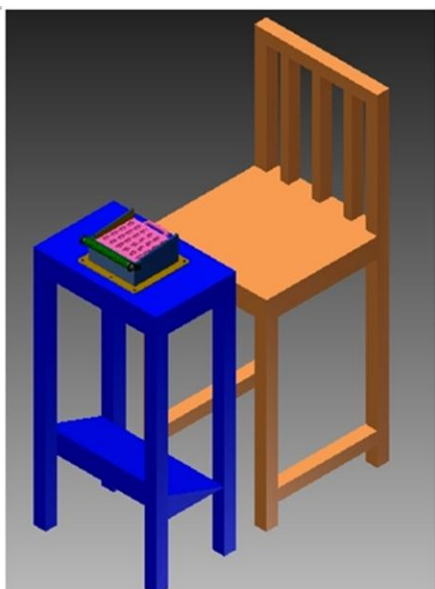

Figure 1a Ergonomically designed cashew nut cracker

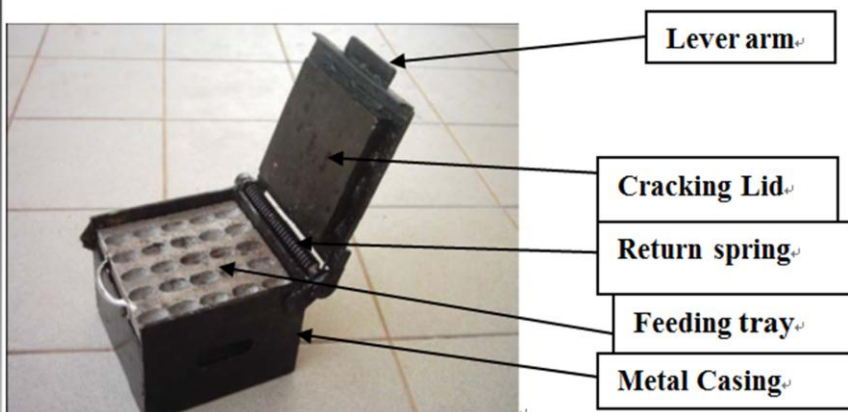

Figure 1b Cashew nut cracking machine

A preliminary investigation was carried out by Ojolo and Ogunsina (2007) to determine some properties such as dimension (length, thickness and width), cracking force and absorbed energy of the roasted nuts; these nuts were shelled and the dimension of the kernels were determined (Table1). Based on the motion of the cracking lid, an average of 20 seconds was assumed for the cracking lid to make contact with the feeding tray. The cross section of the plate is taken as a square length 180 mm. The mean deviation and standard deviation of the samples was calculated so as to determine the spread of the samples around the mean value.

The cross sectional area, A of the cracking plate = 180 mm x 180 mm = 32400 mm²

Table 1 Design parameters of the cashew nut Sheller (Ojolo and Ogunsina, 2007).

Parameters	Mean	Mean deviation	Std deviation
Cashew nut			
Length, mm	30.40	1.36	1.61
Width, mm	20.45	1.14	1.48
Thickness, mm	18.71	0.89	1.08
Kernel			
Length, mm	26.38	1.38	1.56
Width, mm	13.43	0.68	0.86
Thickness, mm	8.00	1.30	1.47
Cracking parameters			
Nut weight, g	5.67	0.83	0.98
Cracking force, N	488.80	33.94	42.31
Absorbed Energy, MJ	1.36	1.14	0.89
Required power, W	1.61	1.48	1.08

Mode of operation of the machine

The cracking lid is opened and the feeding tray is pulled out to load roasted cashew nuts, the tray is pushed back into the metal casing after the loading. On activating the lever, the lid compresses the nuts, leaving it partially closed with a maximum clearance of 2 mm, to prevent crushing the embedded kernels. At this instance all the nuts must have been cracked but the lid will not close up enough to crush the kernels. Immediately the lever is released, the spring returns the cracking lid back to the opening position. When not in use the lid is locked in position with the aid of the hook provided on the casing. This process can be repeated for more nut cracking.

2.2 Experimental procedure

The experiment was based on a participatory ergonomics approach to improve the design of the cashew nut cracking device. This majorly comprises two stages viz;

- 1) Testing of the existing cashew nut cracking device in the field and evaluation of comfort questionnaire.
- 2) Modification of the design of the existing cashew nut cracking device using the feedback from the users and relevant anthropometric data

2.2.1 Sample preparation

The cashew nuts obtained from ABOD (a cashew processing industry located in Ogun state, Nigeria) were subjected to pre-cracking treatments. The pre-treatment of cashew nuts prior to shelling makes the shell more amenable to fracture (Ogunsina and Bamgboye, 2011). The cashew nuts were roasted in batches in hot oil. Each batch was roasted by dipping the nuts inside pre-heated cashew nut shell liquid (CNSL) at the temperature of 190⁰C-200⁰C for 1.5 mins as specified by Ogunsina and Bamgboye (2011). The roasted nuts were discharged on saw dust to remove the residual coating of CNSL on the surface of the shell. Afterward, the nuts were allowed to cool naturally for 18 h.

2.2.2 Study protocol

The following experimental procedures were followed during this study;

- 1) Industrial survey to determine the most suitable location for the study.
- 2) Preliminary trial
- 3) Determination of study population
- 4) Orientation of the subjects on the study and safety procedures
- 5) Description of measurement tools
- 6) Administration of questionnaires
- 7) Analysis of the data
- 8) Evaluation of results

2.2.3 The subjects

The study was carried out in August 2012 at ABOD cashew nut processing company situated at Ikorodu, Ogun state, Nigeria. Fifty subjects were involved in this study. The subjects were selected from the workforce at ABOD. They are experienced in the cashew nut cracking, although with the use of hammer. Their experience in cracking operation made them to appreciate the comfort of using machine in cracking operation. The emphasis was on cracking. It was ensured that the participants have sound mental and physical health. Personal details of the subjects were obtained and the average values for the population were tabulated (Table 1). The focus of

the study and the procedures of anthropometric data collection were vividly explained to the subjects before the measurement started to get cooperation from them and to ensure the accuracy of the measurement

2.2.4 Anthropometric measurement

Thirteen measurements described by Pheasant (1990), that are relevant to the cashew nut cracking device were gathered from the subjects and used in developing a model cashew nut cracking device. Anthropometer and other instruments were used for the measurement of body dimensions. During the measurements, the subjects were without shoes. The measurements were taken in accordance with the procedure described by Pheasant (2003). The measurement techniques and terminologies referred to the guidelines in Anthropometric Source Book (NASA, 1978; Kroemer and Grandjean, 1997; Pheasant, 2003). The Excel spreadsheet software package was used to analyze the data. The data set for each dimension in the sample's groups were checked to ensure that they represent a normal distribution. The values of the mean and standard deviation (SD) were calculated, the 5th, 50th and 95th percentile values were also calculated with the same software.

2.2.5 Postural discomfort

The postural analysis was based on a modified body map (Corlett and Bishop, 1976). Thirteen parts were identified to locate postural discomfort. Due to difficulties in presenting rating scales to illiterate subjects, they were asked whether they felt any pain or discomfort in each body part, with a yes or no response. To avoid any mix up with the names of body parts, the experiment pointed at each area in turn. This was repeated before and after cracking. Pain was defined as any numbness, stiffness, tingling, pulling, burning or aching. The specified area of study identified based on the preliminary trial are as follows; neck, shoulder, upper arm, fore arm, wrist, upper back, waist, thigh, lower leg, feet, buttock, fingers.

2.3 Comfort questionnaire for cashew nut cracking machine (cqc)

The subjects were asked to crack 18.1 kg (approximately 2745 nuts) of cashew nuts. After the subject had finished the cracking operation, the descriptors of the comfort questionnaire were rated and (where necessary) the meanings of the descriptors were explained. At last the subject rated the overall comfort.

2.3.1 Work rate

The time required to crack 18.1 kg of cashew nuts was recorded as an indication of work rate. Weight was measured using a digital balance. The entire subjects were instructed to operate the machine for an hour based on the preliminary trial.

2.3.2 Maximum working heart rate

Heart rate was measured using heart rate monitors and logged at one minute intervals. Resting heart rates were measured, and maximum heart rate was estimated according to the formula $220 - \text{age}$ (Rodahl, 1989). To enable a more meaningful comparison, individual differences between subjects were minimized by expressing working heart rates as a percentage of an individual effective heart rate range. This was calculated from resting and predicted maximum heart rates. Therefore the maximum working heart rate formula is defined as follows;

$$WHR_{MAX} = (HR_{MAX} - RHR) \times 0.85 \quad (1)$$

$$HR_{MAX} = 220 - \text{age} \quad (2)$$

$$\text{Effective Heart rate} = \frac{WHR_{MAX}}{HR_{MAX}} \quad (3)$$

Where, WHR_{MAX} is the percentage maximum working heart rate

HR_{MAX} is the maximum heart rate (beats per min)

RHR is resting heart rate (beats per min)

3 Results and discussion

3.1 Anthropometric measurements

The personal details and anthropometric characteristics of the subjects selected for this study are

as presented in Table 2 and 3. The subjects were selected from the workforce that process cashew nuts at the industry. They were selected on the basis of their experience in cashew cracking operation. This was done to ensure a close comparison between the manual cracking and the machine operation. The mean age of the population is 28.09 years; the mean weight is 62.26 kg; while the average height is 1612.78 mm. Also the average resting heart rate 64.94 beats per minute and the average maximum heart rate is 190.92 beats per minute (bpm). In Table 2, the 5th and 95th percentile values are presented.

Table 2 Personal details of the subjects from ABOD cashew processing industry

Subjects	Age	Sex	Weight, kg	Height, mm	Resting heart Rate, bmp	Max Heart rate, bmp
1	27	M	72	1798	62	193
2	31	M	64	1600	70	189
3	28	M	66	1798	63	192
4	27	M	66	1707	64	193
5	26	M	59	1750	62	194
6	29	M	68	1768	65	191
7	22	M	60	1680	62	198
8	31	M	60	1750	65	189
9	25	M	70	1798	64	195
10	29	M	73	1700	67	191
11	25	M	68	1676	64	195
12	25	M	68	1770	63	195
13	29	M	63	1768	65	191
14	32	M	66	1706	68	188
15	28	M	65	1798	63	192
16	25	M	56	1524	65	195
17	27	M	72	1800	62	193
18	21	M	59	1560	62	199
19	18	F	50	1540	65	202
20	30	F	51	1570	71	190
20	31	F	56	1524	63	189
22	20	F	53	1522	64	200
23	39	F	58	1646	65	181
24	28	F	50	1500	64	192
25	35	F	68	1524	64	185
26	41	F	60	1554	76	179
27	33	F	62	1615	62	187
28	30	F	69	1640	63	190
29	32	F	78	1640	64	188
30	40	F	60	1520	78	180
31	19	F	55	1554	63	201
32	31	F	57	1524	64	189
33	30	F	64	1524	62	190
34	22	F	54	1585	64	198
35	34	F	68	1600	64	186
36	42	F	58	1615	74	178
37	18	F	46	1372	61	202
38	37	F	70	1524	70	183
39	42	F	78	1524	71	178
40	38	F	65	1615	63	182
41	21	F	56	1502	62	199
42	23	F	50	1550	65	197
43	25	F	60	1370	61	195
44	29	F	65	1650	63	191
45	35	F	63	1620	68	185
46	18	F	60	1524	62	202
47	27	F	66	1600	63	193
48	39	F	64	1550	65	181
49	34	F	69	1690	65	186
50	26	F	55	1400	62	194
Mean	29.08		62.26	1612.78	64.94	190.92
SD	6.461		7.28	112.45	4.33	7.58

Table 3 Anthropometric of selected subjects

Percentile	Men (n=18)				Women (n=32)					
	5 th	50 th	95 th	SD	5 th	50 th	95 th	SD	Min	Max
Stature	1554.6	1554.6	1798.3	84.8	1387.4	1550	1647.8	75.5	1387.4	1798.3
Shoulder(Acromial) height	1314	1450	1560.5	80.6	1195.5	1365	1420	83.2	1195.5	1560.5
Elbow height	1059.5	1130	1300	72.7	895.5	1050	1194.5	86.4	895.5	1300
Knuckle height	670	760	918	83.0	577.5	700	763.5	67.8	577.5	918
Forward fingertip reach	720	800	900.3	55.1	586.5	730	824.5	77.9	586.5	900.3
Fore arm hand (Elbow to fingertip) length	430	505	625.5	76.2	320	465	520	65.3	320	625.5
Shoulder(Bideltoid) breadth	380	440	613	68.6	385.5	445	487.3	36.0	380	613
Popliteal height	350	430	525	68.8	401.1	440	500	34.8	350	525
Thigh thickness	500	570	715	73.0	416.5	510	584.5	51.1	416.5	715
Knee height	388.5	470	586.5	76.4	445.5	500	570	46.9	388.5	586.5
Hand length	150	190	224.5	34.3	140	195	215	14.8	120	224.5
Grip Diameter(Inside)	28	30	35	2.7	2.7	3	3.3	2.2	2.2	35
Palm length	99.1	114.5	151.5	17.5	100	120	140	17.3	99.1	151.5
Hand breadth	88.5	110	150.75	19.8	96.65	102.5	120	8.9	88.5	150.75

3.2 Postural discomfort

The mean and percentage frequency of reporting for the subjects which represent the population of cashew nut cracker operators are as shown in Table 4. The “success” indicates the number of users that had no complain of any pain at the listed body parts, while the “failure” indicates the number of users with complain of pain at the listed body parts. After using the equipment, maximum number of population representing 96% felt pain on their

wrist. This is due to the repetitive motion of the wrist when closing the cracking lid. 80% of the population felt pain on their; shoulder, upper arm, forearm, and knee. This was felt mostly by the subjects that maintain stooping position during cracking operation. Also, above 60% of the population felt pain on their neck and upper back of their body. These results indicate that the wrist, shoulder, upper arm, forearm and knee were mostly implicated and loaded during cracking operation.

Table 4 Body parts' comfort consideration at the end of the cracking operation

PART	SUCCESS (NO)	FAILURE (YES)	% (YES)	% (NO)
Neck	20	30	60	40
Shoulder	10	40	80	20
Upper arm	10	40	80	20
Fore arm	10	40	80	20
Waist	9	41	82	18
Wrist	2	48	96	4
Thigh	35	15	30	70
Upper back	19	31	62	38
Lower leg	25	25	50	50
Feet	30	20	40	60
Buttock	40	10	20	80
Knee	10	40	80	20
Fingers	6	44	88	12

3.3 Comfort questionnaire for cashew nut cracking machine (cq)

Comfort questionnaire for cashew nut cracker operator gives the capacity of the worker to work with the

machine and also their level of satisfaction. It was noted that the major part of the users that maintain the stooping position during the cracking operation could not finish the cracking, this was due to the severe pain at their waist.

The overall comfort rating of the subjects in Figure 2b indicates that 50% of the users are just “averagely comfortable” with the earlier machine while the remaining 50% are either “uncomfortable” or “comfortable”. From Figure 2a, more than thirty subjects were “somewhat satisfied” and accepted that;

- 1) The machine is simple in use.
- 2) It needs a hand grip.

- 3) It is very easy to move.
- 4) It is usable in the absence of electricity.
- 5) Operable with both left and right hand.

However, the perception of the subjects as per the efficiency of the machine was between the two extremes. 40% were fully satisfied with the efficiency of the machine, while the other 40% were unsatisfied.

Comfort ratings for cashew nut cracking operation

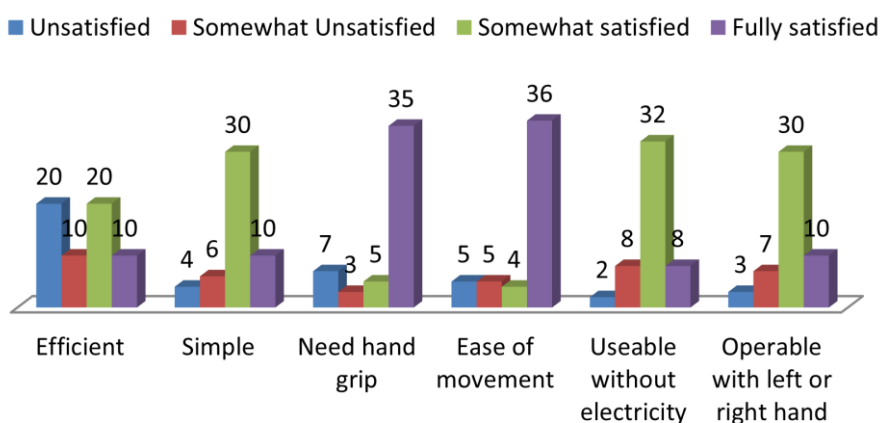

Figure 2a Overall comforts rating of the subjects

OVERALL COMFORT RATINGS

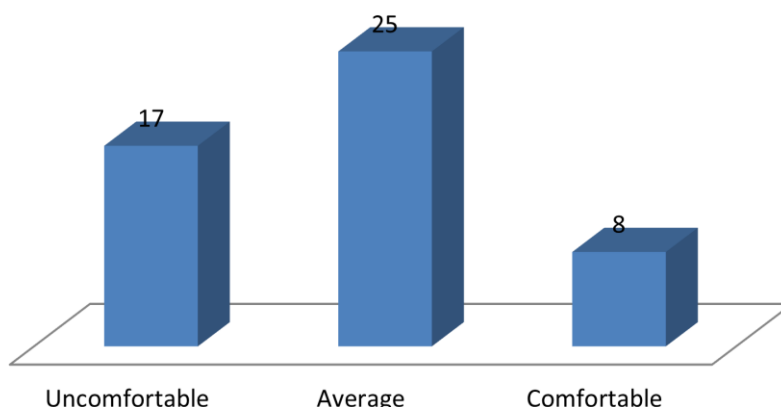

Figure 2b Overall comforts rating of the subjects

3.4 Work rate

The work rate was significantly faster when compared with the manual method used at ABOD. The average subjects were able to crack 18.3 kg of cashew nuts in an hour as against 15 kg that can be cracked by

most experience operator using manual method in an hour. Eight subjects withdrew from the operation after 45 mins, complaining of fatigue and discomfort.

3.5 Heart rate

The resting, working, and maximum working heart rate is shown in Figure 3. All the resting heart rate falls within the range of 60-100 bpm which is normal (<http://www.medicalnewstoday.com/articles/235710.php>). Kapitaniak (2001) explained that despite the great

variations in heart rates due to intra-individual differences, the majority of people display average resting heart rates between 60 and 90 beats per minute (bpm). This indicates that all the users selected for this experiment be assumed to be in good condition of heart.



Figure 3 Heart rate of the subjects

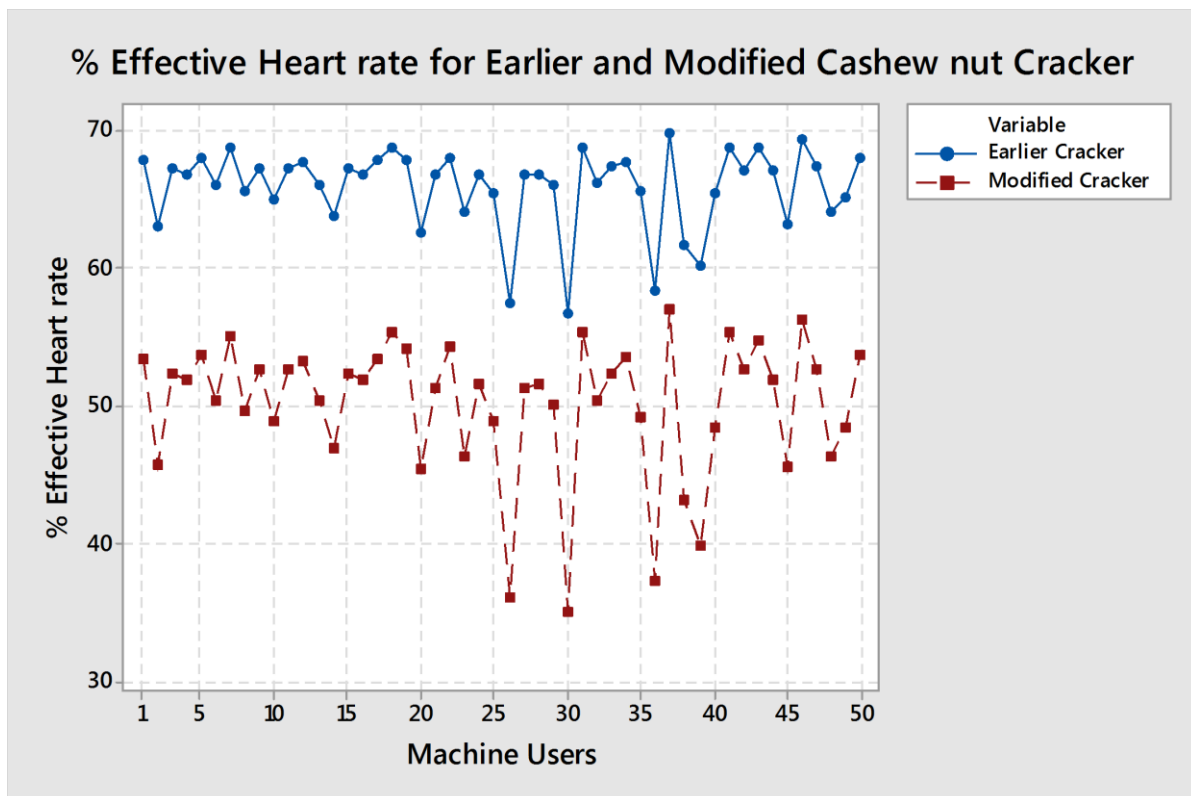

Figure 4a Comparison of % effective heart rate for the earlier cracker and modified cashew nut cracker

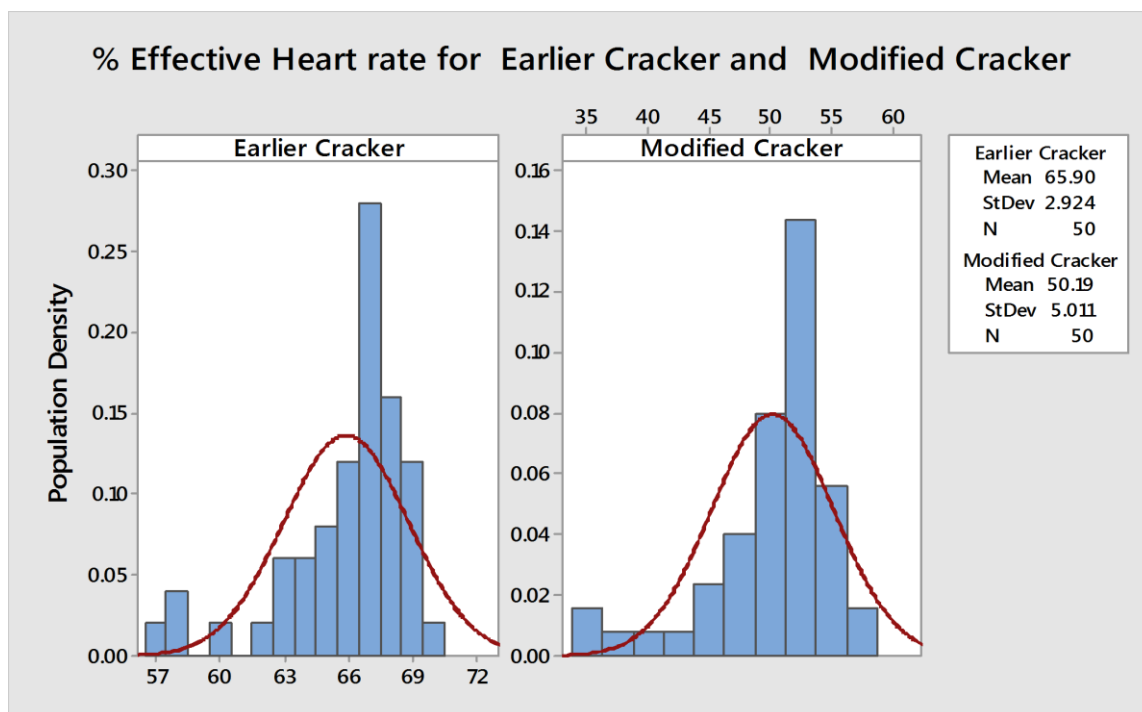

Figure 4b Mean and standard deviation of the Earlier and Modified cracker

4 Ergonomic design of the cashew nut cracking machine

After review of various components of a cashew nut cracking machine, it was discovered that there are some components that need to be redesigned for better performance. The features considered for ergonomic design of cashew nut cracking machine include;

- 1) Lever arm
- 2) Feeding Tray
- 3) Cracking lid
- 4) Ergonomic seat and work table.

4.1 Lever arm

A properly designed grip help to reduce fatigue and pain, and it instantly feel comfortable in the hand. The present lever arm does not allow a firm grip that is why the user feels pain on their wrists. The lever arm was changed to the hand grip that allows the fingers to coil

around the handle. Based on anthropometric data of hand, the diameter of the hand has been fixed so as to achieve better grip facilities. The hand grip makes a fist with four fingers on one side and the thumb on the other side. The hand grip is designed to be used by the people using left or right hands. The right-sized handle is one that allows the hand to go more than halfway around the handle without the thumb and fingers meeting (Mahendra et al, 2010). The recommended grip diameter is based on the 95th percentile of the population with allowance of 0.1 mm. A value of 35 mm is selected. The material selected for the handle is mild steel. The grip surface of the hand grip should be smooth, non-conductive, and slightly compressible to dampen vibration and better distribute hand pressure. So, the grip surface is insulated with rubber because it is strong and comfortable enough to prevent crack and injured hand (Figure 5).

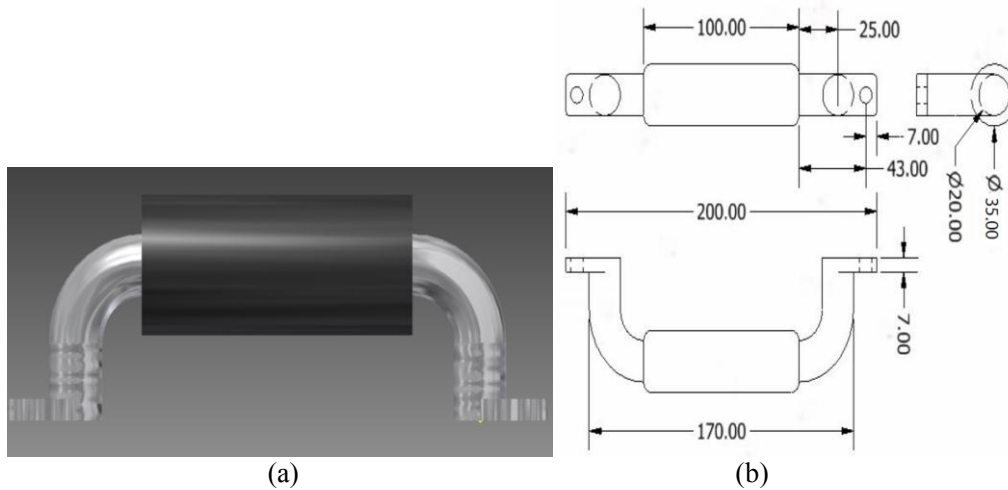

Figure 5 Ergonomic Lever arm

4.2 Feeding tray

The blade was incorporated into the feeding tray. This was done to ensure that the cashew nut is neatly cracked without damaging the kernel due to several impacts of the cracking lid on the nuts. The feeding tray is made of cast aluminum plate, with mild steel blade inserted into each groove. The thickness of the blade is 1 mm. The tray is supported on both sides by flat plate made of mild steel welded to the main body to allow easy sliding of the feeding tray.

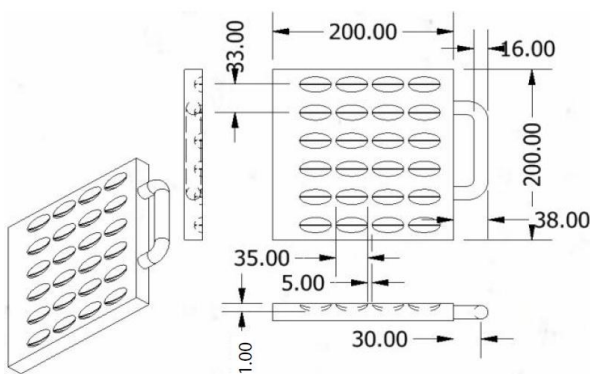
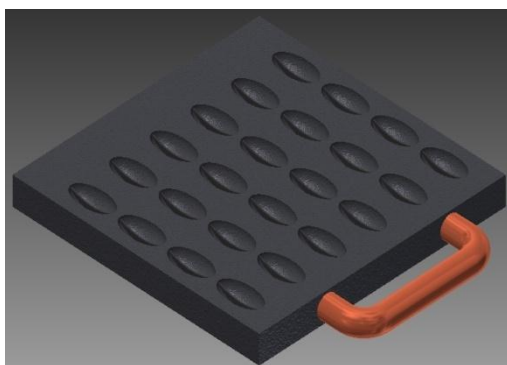
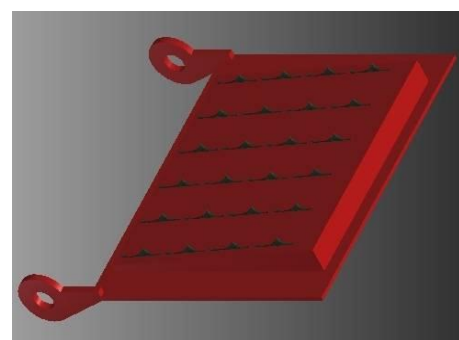

Figure 6 Feeding tray

4.3 Cracking Lid

The cracking lid is machined and dimensioned such that the working part that is in direct contact with the cashew nut is of varied extension into the box. A clearance of 20 mm is allowed on each side of the lid. This serves as a guide, and also ensures that the force exerted on the cashew nut is not excessive. The extended part of the cracking lid was stepped (made of varied thickness) so as to ensure even contact between the cracking lid and the cashew nuts. The blade was also welded to the cracking lid so that some level of shearing is achieved in the course of cracking operations. The thickness of the blade is 1 mm. The geometry of the blade is such that it mirror the kidney shaped section of the cashew nut (Figure 7). The average compressive force required to crack 25 nuts in a batch was calculated to be 488.8N (Ojolo and Ogunsina, 2007). And since it is less than tensile strength of the mild steel, the mild steel was selected for the lid due to its low cost and availability.



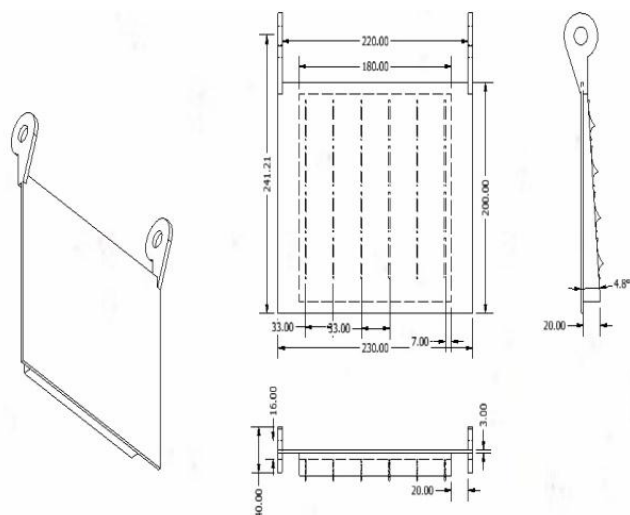

Figure 7 Cracking lid

4.4 Ergonomic seat and work table

A stooping posture adopted by some users during cracking operation is undesirable, with spinal flexion causing deformation of the intervertebral disc and exerting a risk of the nucleus been extruded (Pheasant, 1991). The working height of the machine was raised so as to reduce the angle of flexion, hence, reduction in musculoskeletal pain or discomfort following cracking operation. Grandjean et al. (1997) recommended that the work table could range between 711 mm to 1092 mm depending on whether the table is meant for light, precision, or heavy work. This was clearly explained to mean 102 mm to 152 mm below the elbow height (www.site.iugoz.edu.ps/ddagga/file/201). The work surface height is designed based on 5th percentile of the users. The work surface height is made to be 100 mm below the elbow height i.e. 1200 mm. The length of the work table (work space) was designed to accommodate 95th percentile of the shoulder (Bideltoid) breadth of the subjects. The foot and the knee room was 150 mm. The foot rest was provided to allow operator’s foot to be normal to the lower leg at an angle of 25⁰. The foot rest is based on 95th percentile propliteal height of the female population, so, it is 500 mm above the finish floor level,

and it was made adjustable by 100 mm to accommodate other users (Figure 8).

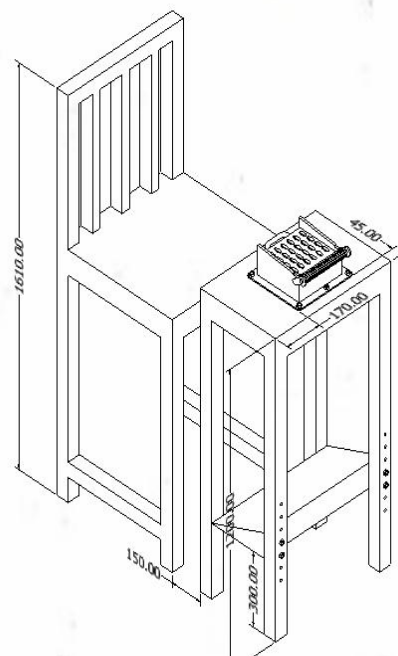
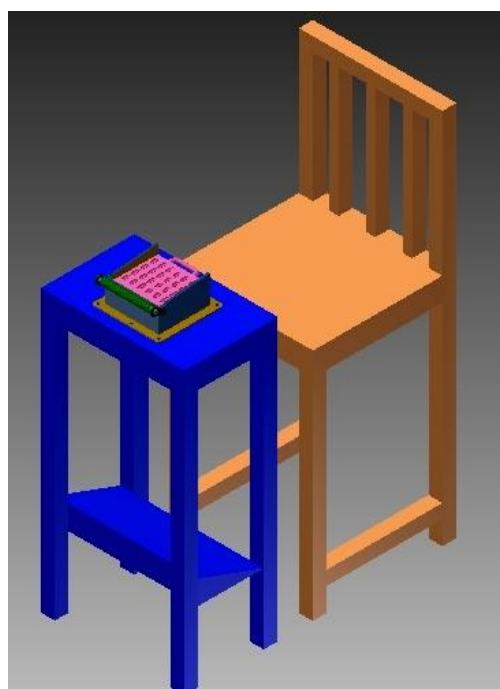

Figure 8 Ergonomically designed work table and seat

4.5 Physiological workload

In order to determine the performance of the modified cashew cracking device, the physiological workload was determined. This enabled us to compare the performance of the earlier cracker and the modified cracker that was designed base on ergonomic considerations. The most common physiological

measurement of workload is heart monitoring. Heart measures are often used because they are easy to evaluate and are considered a fairly reliable indicator of workload. This measure can also be used in real-world environments because the measurements are unobtrusive and continuously available (Wilson, 1992). Heart rate monitors is a common means of determining the degree of physical exertion. Vuori (1998) discovered that the constant fluctuations in heart rates occur due to changes in breathing rate, blood pressure, hormones, various actions of the sympathetic and parasympathetic nervous systems and emotional states, as well as working postures, environmental influences and health status, complicating the analysis of heart rate responses due to a specific activity alone. The mean of physiological workload, was expressed as a percentage of an individual's effective heart rate when operating the machine. An overview of figure 4a, reveals that the effective heart rate is lower for modified cracking machine at all instances and for all the users. The percentage effective heart rate reach its maximum for a user at a value of 69.8% when cracking with the Earlier cracker, while the maximum value for the Modified cracker is 57%. This suggest that the workload of the subject that are operating the machine has reduced. It was discovered that the mean physiological workload was 50.2% compared with 65.9% for the earlier version of this machine (Figure 4b). There was a significant reduction of 15.7% in the mean effective heart rates when cracking with the modified machine.

5 Conclusions

The benefits of using a participatory ergonomics approach were clearly demonstrated in this study. The main objectives of this study have been; to enhance the effectiveness and efficiency with which cashew nut cracking are carried out. These include such things as increase convenience of use, reduced errors, and increased productivity. It also seeks to identify and rectify the risk factors associated with the use of cashew nut cracking machine. To achieve these objectives, the study

identified some part of the machine in need of modification based on the feedback from the users in consideration of desirable ergonomics factors. Postural discomfort analysis indicated that the wrist, shoulder, upper arm, forearm and knee were mostly implicated and loaded during cracking operation. With the modified cashew nut cracking machine, the reportage of postural discomfort by the users reduced from 96.1% to 15%

The study identified; the need for hand grip and comfortable sitting arrangement as some of the ergonomic factor that are to be addressed. The entire subjects easily operated the modified cashew nut cracking machine with either left or right hands.

It was discovered that the mean physiological workload was 50.2% compared with 65.9% for the earlier version of this machine. This is due to reduced physical exertion as a result of more comfortable cracking machine. In the process of making better machine, the new cashew nut cracking machine has been shown to be better than the existing one. It provides an improved working environment and a reduction in workplace injuries which subsequently lead to improved labor productivity.

References

- Bridger, R. S. 1995. Introduction to Ergonomics. McGraw- Hill, New York.
- World Engineering Congress 2010, 2nd – 5th August 2010, Kuching, Sarawak, Malaysia
- Conference on Manufacturing Technology and Management
- Chou, J. R., and S. W. Hsiao. 2005. An anthropometric measurement for developing an electric scooter. *International Journal of Industrial Ergonomics*, 35(11): 1047-1063.
- Corlett, E.N., & Bishop, R.P. (1976). A technique for assessing postural discomfort. *Ergonomics*, 19, 175-182.
- FAO Statistics. 2004. Cashew. www.uga.edu/fruit/cashew.html. (Accessed on June 14, 2013, New York).
- Grandjean, E., K. Kroemer, K. H. E. Kroemer. 1997. *Fitting the task to the human*. London: Taylor & Francis.
- Kölsch, M., A. Beall, and M. Turk. 2003. Postural comfort zone for reaching gestures. www.cs.ucsb.edu (Accessed on June 21, 2013)

- Kapitaniak B 2001. Heart rate as strain index. In: W Karwowski (Ed.): *International Encyclopaedia of Ergonomics and Human Factors*. London: Taylor and Francis, P. 323.
- Lin, Y. C., M. J. J. Wang, and E. M. Wang. 2004. The comparisons of anthropometric characteristics among four peoples in East Asia. *Applied Ergonomics*, 35(2): 173-178
- Mahendra, S. K., and B. Awadhesh. 2010. Design, development and ergonomics evaluation of hand operated spade (PHAWRA). *Ergonomics Australia*, 24(1): 875
- McNeill, M., and A. Westby. 1999. Ergonomics evaluation of a manually operated cassava chipping machine. *Applied Ergonomics*, 30(6): 565-570.
- NASA. 1978. Anthropometric Source Book [NASA Reference Publication 1024]. Webb Associates, Yellow Spring, Ohio, USA.
- Ogunsina, B. S., and A. I. Ajayi. 2011. Crackability and whole kernel out-turn of pre-heated cashew nuts using a hand operated knife cutter. *Proceeding of the 11th International conference and 32nd Annual General Meeting of the Nigeria Institution of Agricultural Engineers*, Oct.17-20, 2011, Ilorin, Nigeria.
- Ogunsina, B. S., and P. O. Odugbenro. 2005. Prospects for cashew nut processing industry in Nigeria. *Landwards. Institution of Agricultural Engineers Journal*, 60(4): 2-6.
- Ojolo, S. J., and B. S. Ogunsina. 2007. Development of a cashew nut cracking device, *Agricultural Engineering International. The CIGR E- journal, Manuscript PM 06030* Vol. IX.
- Pheasant, S. 1990. *Anthropometrics: an introduction*, BSI, Milton Keynes
- Pheasant, S. 1996. *Body space: Anthropometry, ergonomics and design of work*. Taylor and Francis, pp. 15-45, 174-193.
- Pheasant, S. 2003. *Body space (2nd ed)*. Taylor & Francis, London.
- Rodahl, K. 1989. *The physiology of work*. Taylor and Francis, London
- Sutton, D. H. 1989. People and technology for development -the human factor in agricultural mechanisation In: Wang Mao-hua (Ed.). *Proceedings of the International Symposium on Agricultural Engineering*, Vol. 1, Beijing, China.
- Sanders, Mark S., and J. McCormick Ernest. 1992, 7th edition, *Human factors in engineering*. In Sue, H. and McAtamney, L. (2000). A technical note on Rapid Entire Body Assessment (REBA). *Applied Ergonomics*, 31: 201-205
- Vuori I 1998. Experiences of heart rate monitoring in observational and intervention studies. *Journal of Sports Sciences*, 16: S25-S30.
- Wilson, G. F. (1992). Applied Use of Cardiac and Respiration Measures – Practical Considerations and Precautions. *Biological Psychology*, 34(2-3), 163-178.